

analyser

the art of measuring

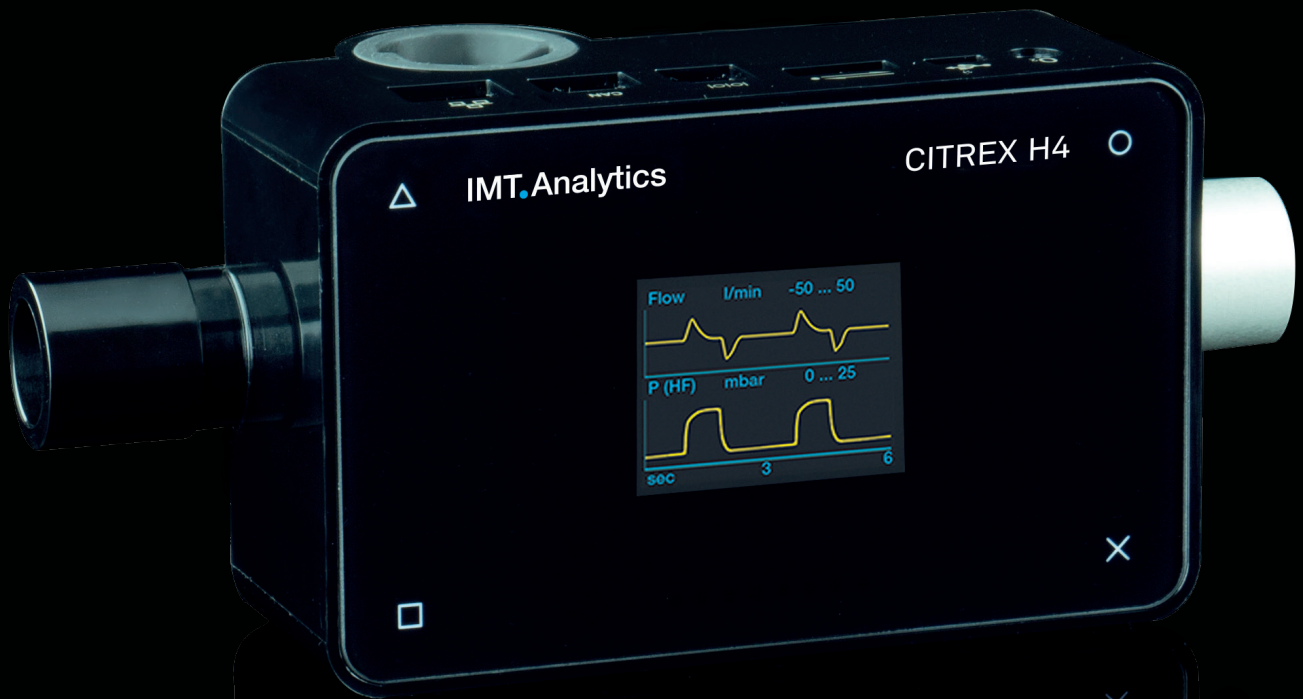

User Manual
CITREX H4

IMT Analytics

IMT Analytics AG
Gewerbstrasse 8
9470 Buchs (SG)
Switzerland

www.imtanalytics.com

Table of Contents

1	Introduction	5
2	Intended use	6
3	Safety instructions	7
3.1	Representation of hazards, cautions and notes	7
3.2	Personnel	7
3.3	Responsibility and guarantee	7
3.4	Service life	7
4	Symbol explanation	8
5	Start-up	9
5.1	Power supply	10
5.2	Mechanical connectors	11
5.3	Electrical interfaces	16
5.4	Change CITREX battery	17
6	Operation	18
6.1	Switching the device on/off	18
6.2	Screen lock	18
6.3	Dim screen	18
6.4	User controls	19
6.5	Settings	20
6.6	Numerical readings	23
6.7	Graphical readings	24
6.8	Filter	25
6.9	Change parameters and units	25
7	Calibration	26
7.1	Zero point	26
7.2	Oxygen (O ₂) calibration	26
8	Connecting the device	28
8.1	General measurement setup	28
8.2	Measurement setup for checking ventilators	29
8.3	Measurement setup for gases at high pressure	29
9	Profile editor	30
9.1	Creating a profile	30
10	Configuration tool	32
10.1	PC minimum requirements	32
10.2	Web server	32
10.3	Monitoring option	33
11	Reading measurement data	35
11.1	Saving measurement data on the microSD card	35
11.2	Reading the data	35

12	Service and care	36
12.1	Preventive cleaning and servicing operations	36
13	Accessories and spare parts	37
13.1	Accessories table	37
14	Disposal	38
15	Directives and approvals	39
16	Specifications	40
16.1	Measurement parameters	40
16.2	Interface definition	42
16.3	Gas type	43
16.4	Power supply	43
16.5	Battery operation	43
17	Appendix	44
17.1	Principle of flow measurement	44
17.2	Trigger	44
17.3	Measurement parameters and units	46
17.4	Gas standards for flow and volume readings	47
17.5	Conversion factors	48
17.6	List of tables	49
17.7	List of figures	49
17.8	Index	50

1 Introduction

CITREX H4 was developed in order to measure flow and various pressures and thus calculate a large number of ventilation parameters. CITREX H4 is a compact, mobile and easy-to-operate measuring instrument. The integrated oxygen sensor makes it possible for users to determine the oxygen concentration. The instrument is controlled using 4 buttons on the front of the device and it has a large number of different interfaces for data analysis.

The descriptions and instructions in this manual refer to the product CITREX H4. In this User Manual the unit "sL/min" is based on ambient conditions of 0°C and 1013.25 mbar in accordance with DIN 1343.

This documentation applies to the following versions:

CITREX H4 software:	4.4.000
CITREX H4 hardware:	4.0

In the case of older or newer versions there may be discrepancies in relation to this User Manual.

Subject to technical modifications without notice.



To avoid possible injuries, please read all the safety instructions before you use the product.



The device is not intended for use outside a building.

2 Intended use

This product is intended for testing and calibration purposes on medical devices or systems that generate gas flows or gas pressures. That includes ventilators and anaesthetic equipment. The user of the device has received training on how to use medical equipment and can perform repairs, maintenance and servicing on medical devices. The device can be used in hospitals, in clinics, at device manufacturers or at independent service companies that perform repairs or servicing operations on medical devices.

CITREX H4 is intended for use in a laboratory environment. It may only be used outside the nursing sector. It must not be used directly on patients or devices that are connected to patients. The measuring instrument CITREX H4 is intended for over-the-counter sale.

With CITREX H4 you have the solution for measurements in the following areas:

- Flow
- Volume
- Differential pressure
- High pressure
- Ambient pressure
- Oxygen
- Temperature

In addition, various ventilation parameters can be measured:

- Ventilation rate
- Time
- Ratio
- T_i/T_{cyc}
- Tidal volume
- Minute volume
- Peak flow
- Pressure
- Compliance
- Trigger



CITREX H4 is a measuring instrument for checking and calibrating ventilators and anaesthetic equipment. It must not be used for patient monitoring. During patient treatment by the ventilator it is not allowed to connect to CITREX H4.

It is not allowed to measure liquids with CITREX H4.

3 Safety instructions

Please read all the safety instructions carefully before you use CITREX H4.

3.1 Representation of hazards, cautions and notes

This User Manual uses the representation below to specifically draw attention to residual risks during intended use and emphasise important technical requirements.

Information and/or instructions and prohibitions to prevent damage of any kind, as well as useful tips and information for handling the device, will be indicated by the following icon:



3.2 Personnel



Work on and with CITREX H4 may only be performed by persons who have undergone appropriate technical training and have the necessary experience.

3.3 Responsibility and guarantee

The manufacturer accepts no responsibility or guarantee and will exempt itself from liability claims accordingly if the operator or any third parties:

- Fail to use the device in accordance with its intended use.
- Disregard the specifications.
- Tamper with the device in any way (conversions, modifications or the like).
- Operate the device with accessories that are not listed in the associated sets of product documentation.



Although the device meets high quality and safety standards and it has been constructed and tested according to the current state of the art, it is not possible to rule out the risk of injuries with serious consequences if the device is used in non-compliance with the intended use (improperly) or is misused.

Therefore please read through this User Manual carefully and keep this documentation in a readily accessible place close to your device.

3.4 Service life

The maximum service life of the device has been specified as 10 (ten) years, provided it is handled properly in accordance with this User Manual.

4 Symbol explanation

The symbols listed below may appear on the packaging material, on the device rating plate and in the User Manual of the CITREX H4 measuring instrument.













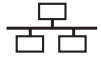



	RS-232 interface
	USB interface
SN BBXXXX	Serial number
	Analog interface
CAN	CAN interface
	Ethernet interface
	On/Off button
	SD card
	Fragile contents
	Keep dry
	Read the User Manual
	The device must not be disposed of in household waste
	The device is CE approved
	Caution: observe the safety instructions in the User Manual
	Reusable packaging
	Manufacturer's specification and date of manufacture
	Keep away from heat
	Temperature range for storage and transport
	CSA monogram with C/US indicator
	California Energy Commission Compliant

Table 1: Symbol explanation

5 Start-up

	CITREX H4
	Power supply plug with country-specific adapters
	USB cable
	MicroSD card
	Dust filter RT019
	Laminar inlet pipe
	CITREX carrying case
	Network cable
	Car adapter
	Adapter set

Table 2: Scope of delivery

5.1 Power supply

CITREX H4 can be operated from the mains or from the integrated battery.

Power can be supplied via the USB port (Mini B), the analog interface or the CAN interface on the top of CITREX H4. Use the power supply unit included to charge the battery or operate the device via the USB port. You will find more information about power supply and how to configure the plugs in the section "Electrical interfaces".

During the charging process a green battery symbol is lit on the front.

Please connect the power supply unit included to a voltage of 100 VAC to 240 VAC with a frequency of 50 Hz to 60 Hz.



Figure 1: Power supply



Before switching on, make sure the operating voltage of the power supply unit agrees with the local mains voltage. You will find this information on the rating plate on the back of the power supply unit. When operating CITREX H4 via the USB port only use the original power supply unit included!



The device indicates visually and audibly when the battery has to be charged. Please do not store the battery in a depleted state.

Caution: depletion can damage the battery beyond repair!

5.2 Mechanical connectors

5.2.1 Flow channel

The flow channel can be used bidirectionally. The positive flow direction is from left to right, viewed from the front of the device. The measurements of volume, flow, gas temperature, oxygen and channel pressure are taken in the flow channel. The values, and the ventilation parameters calculated from them, can be displayed on the screen. You will find the relevant setting options in the section "Operation".

Flow (air)	Measuring range	± 300 sL/min
	Accuracy	$\pm 1.9\%$ of reading or ± 0.1 sL/min
Volume	Measuring range	0–10 sL
	Accuracy	$\pm 2\%$ of reading or ± 0.02 sL
Temperature	Measuring range	0–50°C
	Accuracy	$\pm 1.75\%$ of reading or 0.5°C
Oxygen	Measuring range	0–100 %
	Accuracy	$\pm 1\%$ O ₂
Pressure in flow channel	Measuring range	–50–150 mbar
	Accuracy	$\pm 0.75\%$ of reading or ± 0.1 mbar



Figure 2: Flow channel

5.2.2 Differential pressure

This pressure connector measures the difference in pressure between the two connectors. If only one connector is used for a measurement, pressure measurement takes place at ambient pressure. The measuring range is -200 mbar to $+200\text{ mbar}$. Please comply with the maximum permissible pressure at the connector. The sensor values from this pressure sensor can be displayed in the menu with the parameter "P_{Diff}".

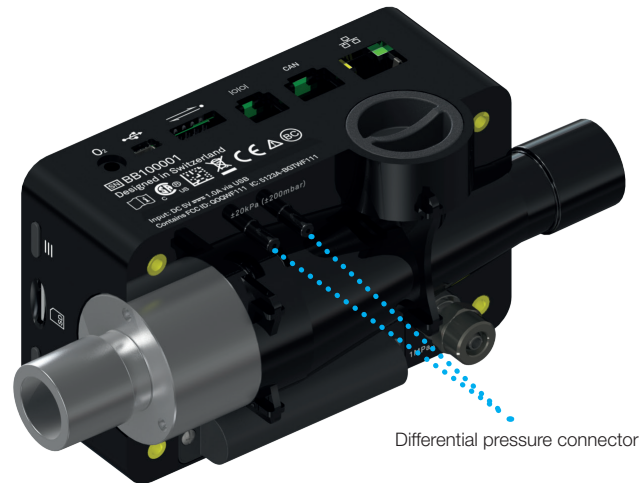

Figure 3: Differential pressure connector

Measuring range $\pm 200\text{ mbar}$

Accuracy $\pm 0.75\%$ of reading or $\pm 0.1\text{ mbar}$



Pressures above 1 bar damage the differential pressure sensor beyond repair!

5.2.3 High pressure

The high-pressure connector measures the applied pressure up to 10 bar. It is recommended that the differential pressure connector be used for measurements up to 200 mbar. It is up to 100 times more accurate. The sensor values measured can be displayed with the parameter "P_{High}".

The high-pressure connector can be fitted with a DISS adapter for air and oxygen. You will find the ordering code in the section "Accessories and spare parts".



Figure 4: High-pressure connector

Measuring range 0–10 bar
Accuracy ±1% of reading or 10 mbar



Pressures above 15 bar damage the high-pressure sensor beyond repair!



Do not use a tool to tighten the adapter on the high-pressure port since this can damage the plastic casing. Please only tighten manually.

5.2.4 Oxygen sensor

CITREX H4 can measure the oxygen concentration in the flow channel. To do so, an oxygen sensor is screwed into the appropriate port. The oxygen sensor has to be connected to the measuring instrument using the cable included. The following steps explain how to install and replace the oxygen sensor.



Figure 5: Oxygen sensor holder

Measuring range 0–100%

Accuracy $\pm 1\%$ O₂ (absolute)

5.2.5 Installing the oxygen sensor

1. Remove the protective cap from the sensor port of the device.



Figure 6: Protective cap

2. Screw the oxygen sensor clockwise into the appropriate port. Make sure the sensor seals off the port and there is no leak.

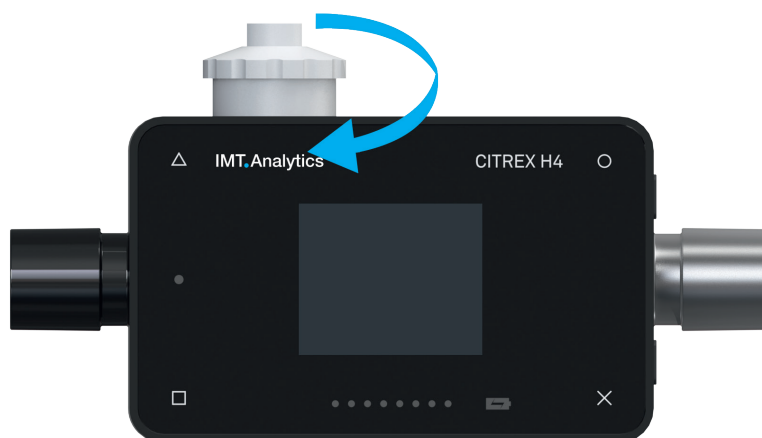

Figure 7: Screwing in the oxygen sensor

3. Connect the cable included to the oxygen sensor by pushing the cable into the hole at the top of the sensor until the cable locks into place. Connect the other end of the cable to CITREX H4 by inserting it into the hole provided, which is labelled "O₂".

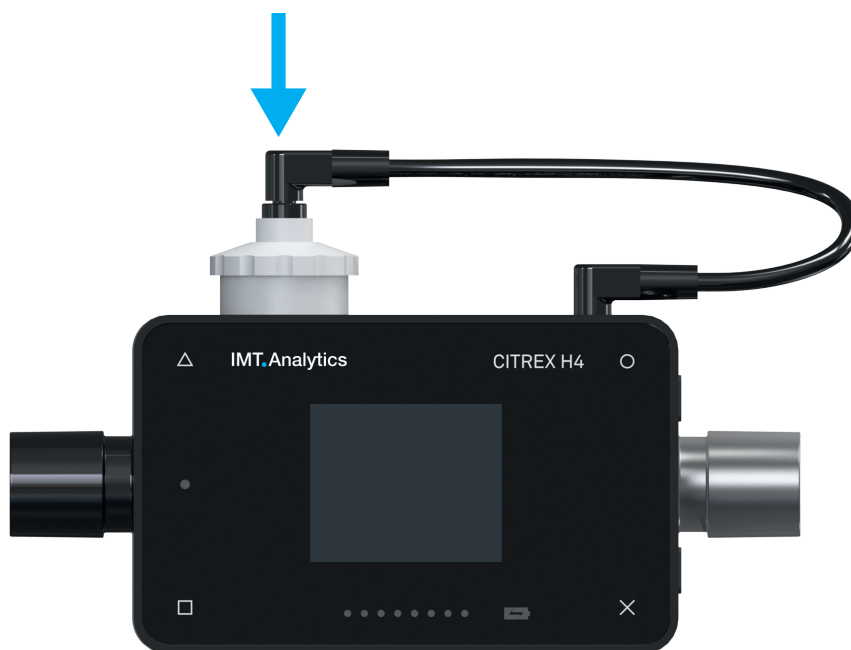

Figure 8: Oxygen sensor cable

4. Perform an oxygen calibration. The calibration procedure is described in the section "Calibration". Calibration ensures that the measured values of the new sensor are correct.

5.3 Electrical interfaces

Figure 9 shows the available electrical interfaces of CITREX H4.



Figure 9: Electrical interfaces

1	MicroSD card slot	The firmware of CITREX H4 is stored on the microSD card. It also contains customised configurations and test reports can be saved on the memory card. You will find more information in the section "Reading measurement data".
2	O₂ interface	The oxygen sensor is connected to CITREX H4 via the O ₂ interface. You will find further information on this in the section "Oxygen sensor".
3	USB port	The USB is used to operate the device from the mains power supply and to charge the device battery but it can also be used as a data interface. It is a "USB Mini-B port".
4	Analog OUT	The Analog Out port is used for reading analog signals. It is also possible to connect an external trigger. Two ports are reserved for mains operation and charging the device battery. You will find the ordering code for the matching connector in the section "Accessories and spare parts". You will find additional technical information about the port in the section "Interface definition".
5	RS-232	The RS-232 port is used as a data interface. In the section "Interface definition" you will find further information about the interface.
6	CAN	The CAN interface is prepared in the device but at present it is not yet supported by the firmware. The CAN interface can be used for charging the device battery. You will find information about the port in the section "Interface definition".
7	Ethernet	The Ethernet interface is used to configure the device and it is used as a data interface. You will find more information in the section "Reading measurement data".

Table 3: Description of electrical interfaces

5.4 Change CITREX battery

The battery of CITREX H4 can be changed by the user. To do so, undo and remove the two screws on the back of the device. Then the battery can be removed and replaced. Check whether the new battery has been inserted properly. For this purpose the terminals must be opposite one another.

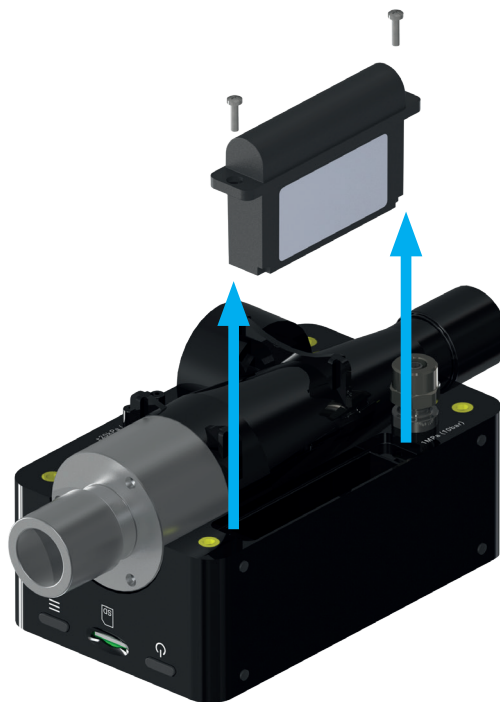

Figure 10: Change battery

6 Operation

This section describes how to use the device and what possible uses there are.

6.1 Switching the device on/off

The device is switched on and off at the On/Off button. Figure 11, section "User controls", shows where this button is located on the device. To switch CITREX H4 on you must press the On/Off button briefly. You will hear an audible signal. To switch the device off you must press the On/Off button for about 1 second. If the device can no longer be controlled, you have the option of pressing the On/Off button for about 6 seconds. The device is then forced to shut down.

6.2 Screen lock

Press the context button on the side of the device for 2 seconds. The screen shows a message indicating that the screen is locked. To unlock the screen, press and hold down the context button or one of the four buttons on the front for 2 seconds.

6.3 Dim screen

If the device is not operated by the user, the display of CITREX H4 shuts down after about one minute and the four buttons start to flash. As soon as a button is pressed, the screen comes on again.

The setting for how long it takes until the display is dimmed can be customised using the configuration tool. You will find further information on this in the section "Configuration tool".

6.4 User controls



Figure 11: User controls

1	Change, Edit
2	Context button; long press: key lock on/off
3	On/Off button
4	Menu button; zero point adjustment
5	Charge indicator
6	Flow direction indicator
7	Screen
8	Measurement values
9	Malfunction indicator
10	Display readings and scroll back

Table 4: User controls

6.5 Settings

With the × button you return to the Settings menu. By pressing the button more than once you can view the various settings of the measuring instrument.

6.5.1 Info display

This display provides information about the owner, the company, the next recommended calibration, the software version and the hardware revision. Settings concerning the owner can be edited with the configuration tool.

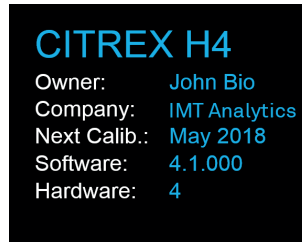

Figure 12: Info display

6.5.2 Battery indicator

The battery indicator informs you about the level of the battery charge.

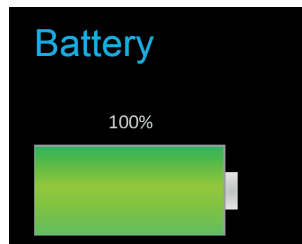

Figure 13: Battery indicator

6.5.3 Ethernet interface

Here it is possible to make various settings for the network connection. With the ○ button you can choose between the options "DHCP Client", "Default" and "Configured". The setting does not have to be confirmed and it is enabled as soon as it is visible on the screen. More information about the settings is available in the section "Web server".

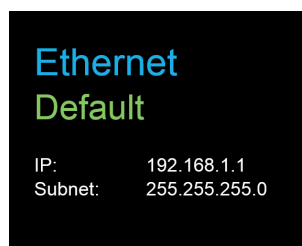



Figure 14: Ethernet interface

6.5.4 Trigger

With the trigger settings the start and end points of a ventilation parameter are defined. Three preset triggers are available. With the  button you can select the trigger "Adult", "Pediatric" or "High Frequency". The trigger settings do not have to be saved and they are enabled as soon as they are displayed on the screen. It is possible to differentiate between flow trigger, pressure trigger and external trigger. The settings can be changed with the configuration tool. You will find further information on this in the section "Configuration tool".

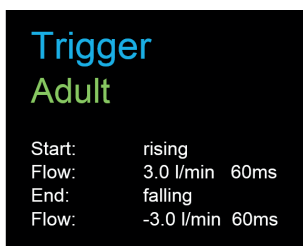



Figure 15: Trigger

The preset trigger settings are defined as follows.

	Adult	Pediatric	High Frequency
Start	3L/min Rising edge	1 L/min Rising edge	3L/min Rising edge
Stop	-3L/min Falling edge	-1 L/min Falling edge	-3L/min Falling edge
Delay	60ms	60ms	10ms
Base flow	0L/min	0L/min	0L/min

Table 5: Trigger settings

6.5.5 Gas standard

The CITREX H4 measuring instrument can convert gas flow and volume readings to various gas standards and display them. Care must be taken to ensure that on the measuring instrument the same gas standard is set as the one on the device being tested. With the  button you can switch between the various gas standards. As soon as a gas standard is displayed, it is enabled. There is a list of available gas standards in the Appendix in the section "Gas standards for flow and volume readings".

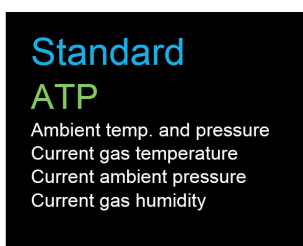

Figure 16: Gas standard

6.5.6 Gas type

Under this menu item the gas type to be measured can be set. With the button you can switch between gas types. The gas type indicated is enabled and does not have to be saved. In the section "Gas type" there is an overview of available gas types. Gas types with adjustable oxygen concentrations, e.g. "Air O2 manual", can be changed with the configuration tool.

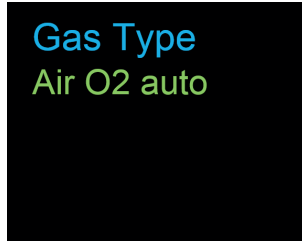

Figure 17: Gas type

6.5.7 Gas humidity

The gas humidity of the gas being measured can be set. This has an impact on gas flow measurement. With the button the gas humidity can be changed in steps of 10. The value is enabled as soon as it is displayed on the screen.



Figure 18: Gas humidity

6.5.8 Setting the X-axis

Here the time axis of the graph view can be set. 2, 4, 6, 8 and 10 seconds are available for selection. The setting can be changed with the button.

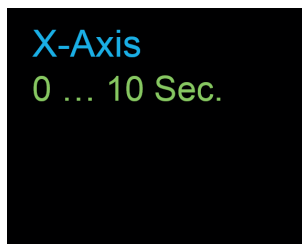

Figure 19: Setting the X-axis

6.5.9 O₂ calibration

The process of oxygen calibration is described in the section "Calibration". With the \circ button you can choose between one-point calibration and two-point calibration. Press the Δ button to start calibration.

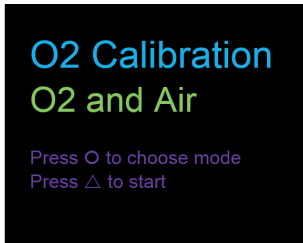

Figure 20: O₂ calibration

6.5.10 Profiles

With this settings item it is possible to call up and load the saved and preset profiles. The \circ button switches between the available profiles and with the Δ button the profiles can be loaded. In CITREX H4 the following profiles are already integrated when delivered: "Factory defaults", "Imperial units" and "Metric units". With the profile editor you can create and save your own profiles. The procedure is explained to you in the section "Creating a profile".

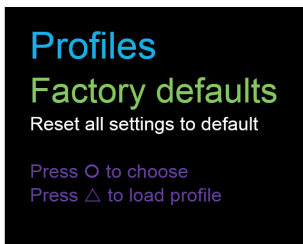

Figure 21: Profiles

6.6 Numerical readings

With the \square button on the front of CITREX H4 you can display the various numerical readings. If you press more than once, the view on the screen changes. The different views can be configured by web server. The web server and how to make the settings are explained in the section "Web server". 1, 2, 4 and 6 readings can be displayed in each configured view.

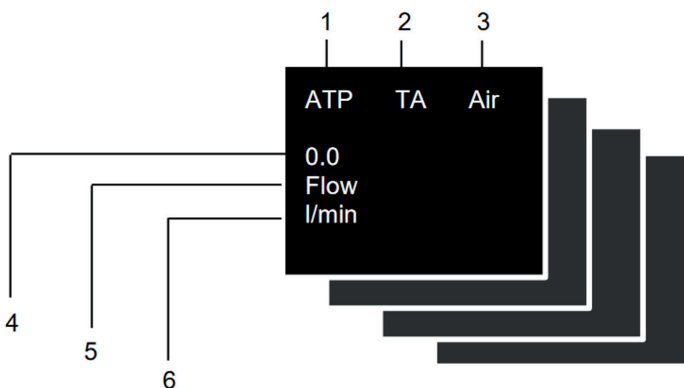

Figure 22: Numerical readings

1	Gas Standard	The measured volume readings or gas flow readings can be displayed with various gas standards. There is a list of standards in the Appendix in the section "Gas standards for flow and volume readings".
2	Trigger signal	The icon appears as soon as a trigger condition is fulfilled. This means that the time of appearance of the indicator is identified as the start of inspiration. The indicator appears for 0.5 seconds. If this signal is not displayed, the trigger settings should be adjusted for the current ventilation mode.
3	Gas type	The gas type currently set is displayed as text. It can be customised on the device under Settings.
4	Reading	This shows the current reading in the selected unit of measurement.
5	Measurement parameter	Indicates the measurement parameter currently selected. Measurement parameters can be changed in configuration; see section "Configuration tool".
6	Measuring Unit	Indicates the unit of measurement currently selected. Units of measurement can be changed in configuration; see section "Configuration tool".

Table 6: Numerical values

6.7 Graphical readings

By pressing the Δ icon on the front of CITREX H4, parameters currently being measured can be displayed in the form of graphs. For each screen view there are one and two measurement curves available for selection. The relevant parameters and units of measurement can be set using the configuration tool. You will find a description of this in the section "Configuration tool".

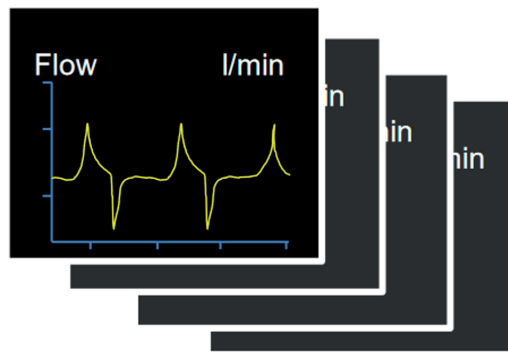

Figure 23: Measurement curves

6.8 Filter





The screen of CITREX H4 is refreshed every 0.5 s. The recording of readings takes place every 5 ms. Since CITREX H4 can record and display readings very quickly, it is advisable to filter the readings. This is performed using a mean value. The extent to which a reading is filtered can be set using the configuration tool.

The following filters are available:

- No filter (indication of the last value measured without any threshold)
- Low (mean above 240 ms)
- Medium (mean above 480 ms)
- High (mean above 960 ms)

The "high" filter is set by default.

6.9 Change parameters and units

If the context button () is pressed twice in succession, "Edit Mode" is enabled. This is indicated by a red icon on the screen. The parameter or unit in the red frame can be changed with the  icon or the  icon. The  icon allows you to jump to the next element. If the context button or the  button is pressed once, you exit "Edit Mode"

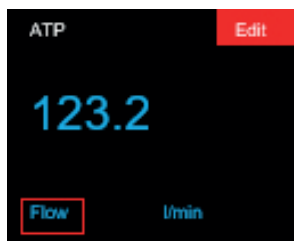

7 Calibration

The various calibration options with CITREX H4 are described in this section. To avoid incorrect measurements you must adhere to the procedures described here.

7.1 Zero point

This adjustment is necessary if indication of the differential pressure sensor (P_{diff}), the high-pressure sensor or a flow through open connection ports shows a value greater or less than zero. This can occur if there are considerable temperature fluctuations, or after the warming-up time. Zero calibration resets all values to zero. To perform zero calibration you must remove all connected tubes from the device. Press the \times icon and keep it pressed for approx. 3 seconds. The screen shows a message "Zero Offset – Calibrating, please wait".

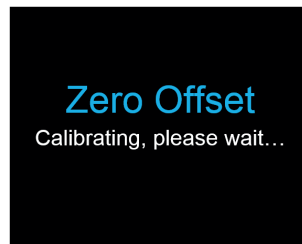

Figure 24: Zero calibration



When you have switched on the device, individual displays may deviate slightly from the zero point until operating temperature has been reached. Zero calibration should never be performed with the device cold. Warming-up time is approx. 10 minutes.



During zero calibration there must be no pressure being applied to a connection port, and care must be taken to ensure that there is no flow through the flow channel.

7.2 Oxygen (O₂) calibration

There are two different methods of calibrating the oxygen cell. The variant in which the oxygen cell is calibrated with air only takes about two minutes. The second variant consists of calibrating the oxygen cell with air and 100% oxygen. This so-called two-point calibration adjusts the oxygen sensor more accurately and takes about four minutes. Calibration can be selected by pressing the \times button more than once.

7.2.1 Calibration with air

Make sure air is flowing through the flow channel at a rate of at least 30 L/min. To start calibration, press the **X** button until you see the menu item "O2 Calibration". With the **O** button you can switch between air and air and oxygen (O₂). Select the **O** button until "Air" appears on the screen in green letters. To start calibration, press the **Δ** button.

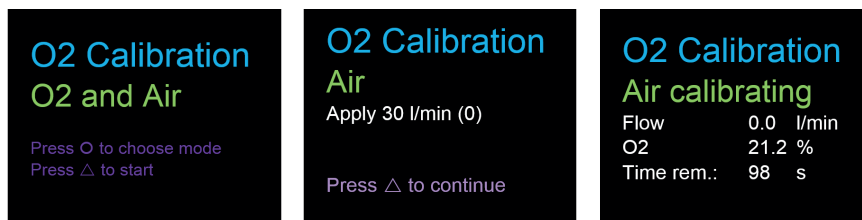

Figure 25: Screen displays "Calibration Air"

7.2.2 Calibration with oxygen and air

For calibration of the oxygen cell with oxygen and air a gas flow of 30 L/min is used in each case. Press the **X** button until you see the menu item "O2 Calibration". With the **O** button you can switch between air and air and oxygen (O₂). Press the **O** button until the screen shows "O2 and Air" in green letters. To start calibration, press the **Δ** button. Calibration for air and oxygen takes 120 seconds for each one.

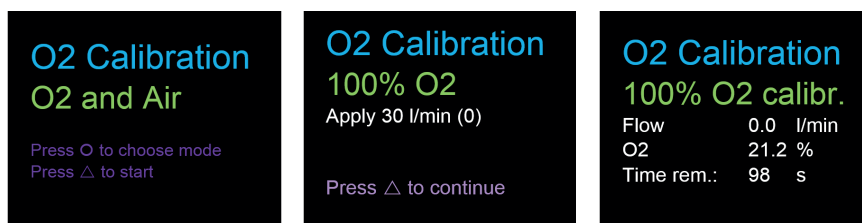

Figure 26: Screen displays "Calibration Oxygen and Air"

8 Connecting the device

The measurement setup for CITREX H4 has an impact on flow measurement. To obtain results that are as accurate as possible, comply with the instructions in this section. It is important to ensure that the tubing in the measurement setup does not have any radii, kinks or dents. You are also recommended to always use the inlet pipe and the dust filter.



The measured gases must be free of oil, grease and dust.

8.1 General measurement setup

The general measurement setup applies to gas flow measurement. The RT019 filter included and the inlet pipe must be used. This ensures laminar flow to the flow sensor unit. The filter also prevents dust, oil and grease from contaminating the CITREX H4 measuring instrument and thus prevents discrepancies in measurement results. The measurement setups shown below are dependent on the direction of gas flow being measured.

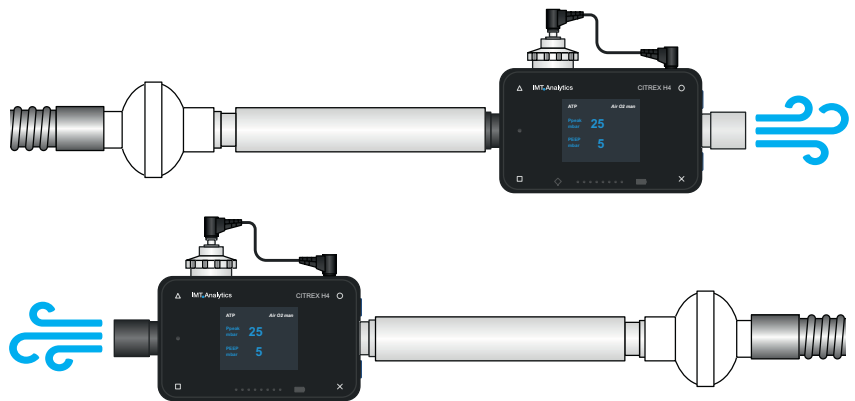

Figure 27: General measurement setup

The measurement setups listed below are unsuitable and produce inaccurate measurement results. Kinks, tees and angle pieces should be avoided in the flow channel. They cause turbulence in the gas being measured and hence inaccurate or incorrect measurement results.

Bad setup: Kinks, tees, angle pieces at the device inlet



Figure 28: Bad setup

8.2 Measurement setup for checking ventilators

CITREX H4 is ideal for checking ventilators. The best measurement results are achieved with the measurement setup shown below. Make sure the test lung is connected to the grey aluminium connection port of CITREX H4.

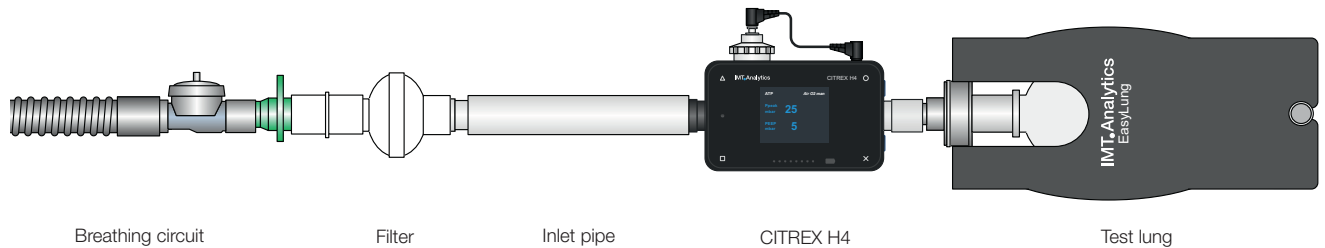

Figure 29: Measurement setup for checking ventilators

8.3 Measurement setup for gases at high pressure

CITREX H4 compensates for the gas pressure during flow measurement. In the flow channel, gas pressures up to 150 mbar are compensated. For gases at higher pressures the high-pressure sensor can be used. For this purpose connect the device outlet to the high-pressure sensor. In the menu "Settings", "Measurement" you must also switch the "Pressure Compensation" setting to "Pressure High".



In the flow channel, pressures up to 150 mbar can be compensated. In conjunction with the high-pressure sensor, pressures up to 300 mbar can be compensated. Pressures in the flow channel above 800 mbar can damage the device.

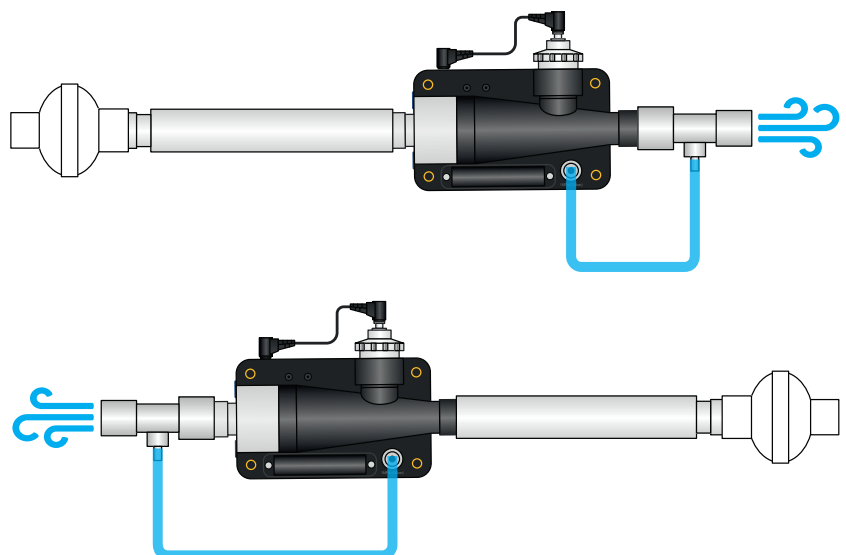

Figure 30: Measurement setup for gases at high pressure

9 Profile editor

The user has the option of saving different profiles to suit personal requirements. To be able to use the profile editor it is essential to have Microsoft Internet Explorer with the browser plug-in Silverlight.

9.1 Creating a profile

To create a profile, remove the SD card from CITREX H4 and connect it to your PC via an SD card reader. Then open the drive of the SD card. There you will find the file "ProfileEditor.html", which has to be opened using Internet Explorer, resulting in the picture below.

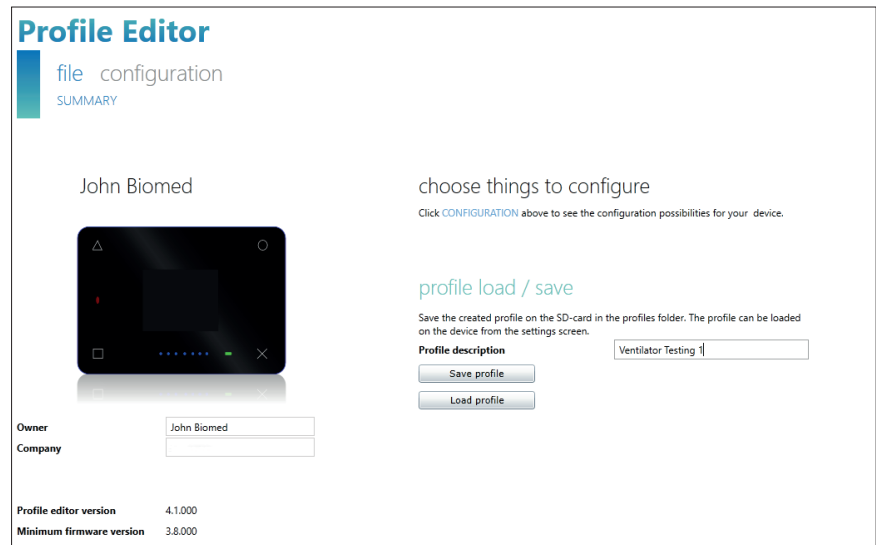

Figure 31: Profile editor in Internet Explorer

Now you can create a new profile by making the settings in the "configuration" menu.

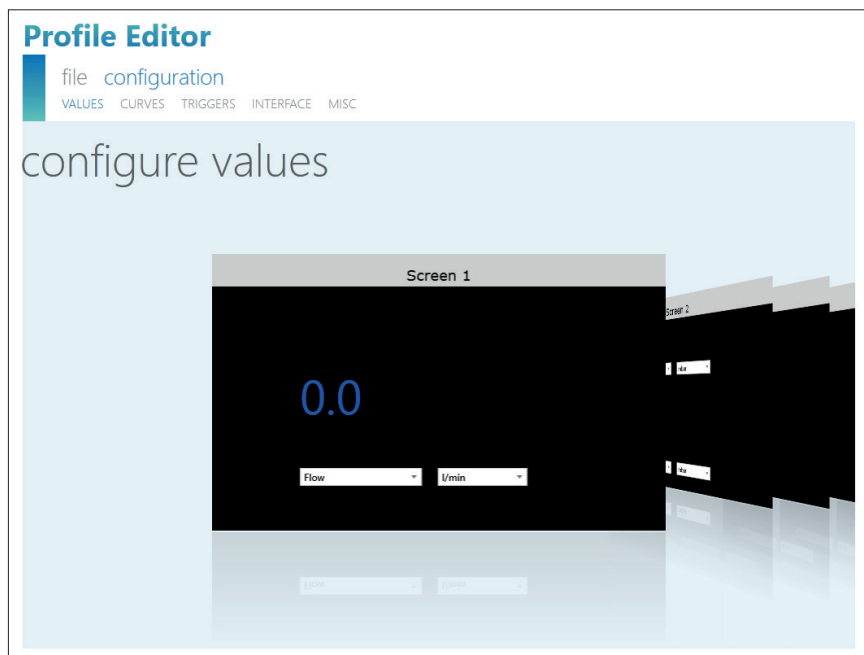

Figure 32: Profile editor "configuration"

This is where parameters, measurement curves, triggers, interfaces, etc. can be defined. These can be saved, as shown in the picture "Profile editor in Internet Explorer". You can also add a description to the profile. Save the new profile with the "Save profile" button. Save the file in the "Profiles" folder on the SD card. When you have saved the new profile on the SD card, place the card back in CITREX H4 and start the device. The newly created profile can be loaded in the "Profiles" menu.

10 Configuration tool

The configuration tool can only be used with Microsoft Internet Explorer.

10.1 PC minimum requirements

Microsoft® Silverlight 5 or higher

Windows x86 or x64 (64-bit mode only supports IE) 1.6 GHz or higher with 512 MB RAM

Macintosh (Intel based) Intel Core Duo 1.83 GHz or higher with 512 MB RAM

Microsoft® Windows® 10, 8.1, 8, Windows Server 2012, 7, 7 SP1, Windows Server 2008 SP2, Windows Server 2008 R2 SP1, Vista

Macintosh OS 10.6 (Intel based), MacOS 10.7 – 10.11 (Intel based)

Ethernet network connection

Screen resolution 1024 × 768 (1280 × 1024 recommended)

10.2 Web server

The Ethernet port on CITREX H4 enables access to the device via a network. The measured real time data can be tracked and analysed on the computer. Settings can also be made on the device via the web browser using the so-called configuration tool. To be able to use the web server it is essential to have an installed Internet Explorer with Microsoft Silverlight 5.

There are three different setting options to establish a connection between CITREX H4 and a computer. Tap the × button until the "Ethernet" menu item appears. You will find a description of the settings in the following sections.

10.2.1 Default

These are default settings that cannot be changed. These settings are recommended in order to establish a direct connection to the computer via an Ethernet cable. The configuration on CITREX H4 is as follows:

IP Address: 192.168.1.1
Subnet Mask: 255.255.255.0

To establish a connection, the network settings on the computer must be changed. For this purpose open the network settings of the computer, which are located in the Control Panel. Then open the "Internet Protocol Version 4 (TCP/IPv4)" settings. Enter an IP address between 192.168.1.2 and 192.168.1.255 and subnet mask 255.255.255.0 in the form on the screen. Confirm with "OK".

Now open Internet Explorer and enter IP address 192.168.1.1 in the address field. The connection to CITREX H4 is established.

10.2.2 Configured

This setting option is suitable for connecting CITREX H4 to a network that does not

have a DHCP server. Define an IP address and a subnet mask using the configuration tool on CITREX H4. When the settings have been confirmed the device can be connected up to the network and be accessed using the defined IP address via Internet Explorer.

10.2.3 DHCP

To connect CITREX H4 to a DHCP server, first connect CITREX H4 to the network. In the "Ethernet" menu select the setting "DHCP" and confirm it with "OK". With the IP address shown on the display it is possible to establish a connection to CITREX H4 via Internet Explorer.

10.3 Monitoring option

In the "Monitoring" menu item it is possible to access the measurement data of CITREX H4 via the network. Either numerical readings or graphical measurement curves can be selected.

10.3.1 Numerical readings

Here it is possible to directly track real-time measurement data on the computer monitor. Both current readings and a minimum, a maximum and a mean are calculated for each reading. Statistical analysis can be restarted by pressing the "Reset" button. There is also the option of exporting the readings currently being displayed. To do this, press the "Export" button: an Explorer window opens in which you can select the storage location and the storage type. There are XML files (*.xml) and CSV files (*.csv) available for selection.

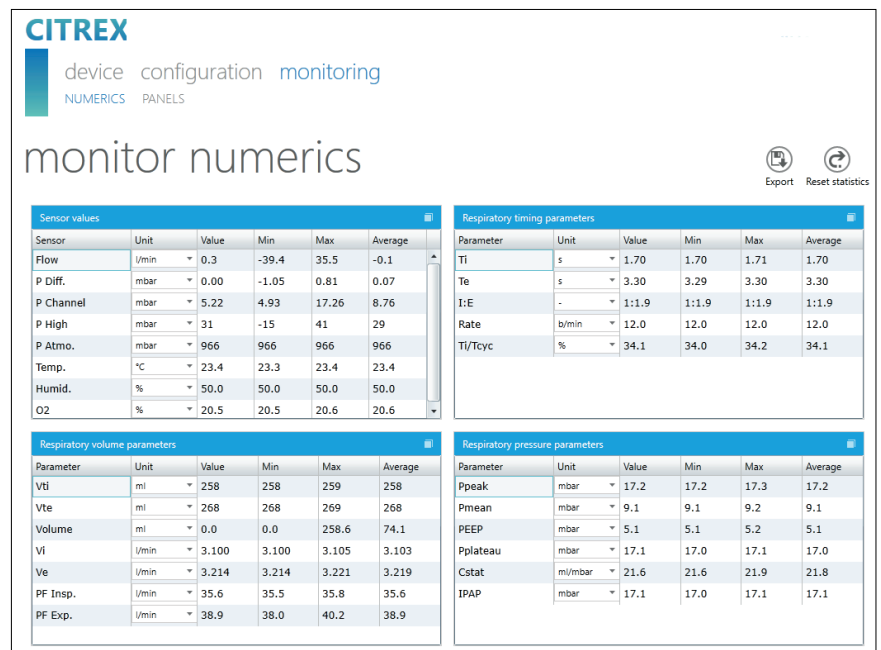

Figure 33: Monitoring numerics

10.3.2 Graphical readings

Here it is possible to directly track real-time curves on the computer monitor. Select the required reading using the pull-down menu. By pressing the "Run" button it is also possible to record readings for 300 seconds. Recording can be terminated by pressing the "Freeze" button. If you have recorded a measurement, you can move the slider into the desired measuring time in order to analyse the period here. Incidentally, it is not only the displayed measurement curves that are recorded; all the readings available for selection are also recorded. There is also the option of exporting the measurement curves currently being displayed. To do this, press the "Export" button: an Explorer window opens in which you can select the storage location. The curves can be saved in the form of a PNG file.

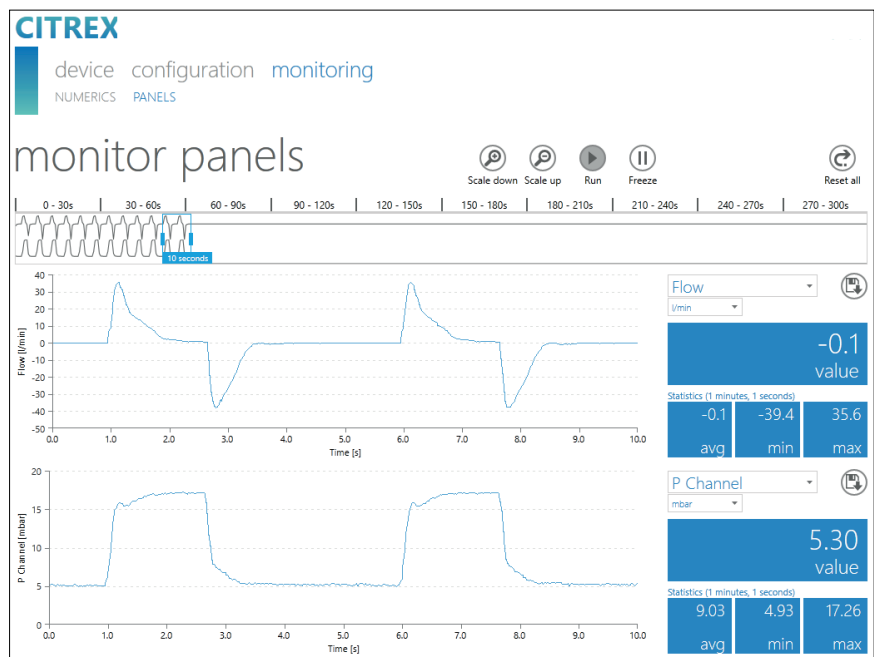

Figure 34: Monitoring panels

11 Reading measurement data



The files on the microSD card must not under any circumstances be renamed or deleted.



Measurement data can be read via the microSD card, via the Analog OUT interface or via the RS-232 interface. For information about using these interfaces please contact your dealer or IMT Analytics directly.

11.1 Saving measurement data on the microSD card

Press the  button and keep it pressed for approx. 3 seconds. A snapshot of all the parameters is taken in a CSV file and saved on the SD card.

11.2 Reading the data

The data can be read directly from the SD card. For this purpose you must disconnect the SD card from CITREX H4 by pressing the SD card once. It is possible to connect the card to your computer directly using an SD card reader.

The memory card of CITREX H4 contains the following data and folders.

Folder or file	Description
DATA	In this directory you will find the readings that have been saved.
LOGS	CITREX H4 continuously records information about its functions and saves it in the form of log files. This data is only used for remedying malfunctions and resolving issues.
*.CFG, *.SCR, *.TRG files	CFG, SCR and TRG files are required by CITREX H4 to activate internal processes.
Formatter\SetupReportFormatter.bat	This batch file is required to format saved data in an Excel file.
Formatter>AboutReportFormatter.txt	This TXT file describes the procedure for formatting saved data in an Excel file.
Formatter\ReportFormatter.xlsb	This is the actual Excel file template in which the saved data is formatted.
Clientaccesspolicy.xml	This file is required for the configuration tool.
index.html	This file is required for the configuration tool.
USB-Driver\usb_cdc_ser.inf	Driver for the USB device identification.

Table 7: Folder structure of CITREX H4

12 Servicing and care

Careful servicing in compliance with the instructions is essential for ensuring that CITREX H4 operates safely and efficiently. Only components recommended by the manufacturer may be used.



It is absolutely essential to comply with the guidelines and servicing instructions issued by the various manufacturers.



The servicing operations listed below may only be performed by persons who are familiar with CITREX H4. All further repair work may only be performed by authorised trained professionals. Please also observe the information issued by the various manufacturers.

12.1 Preventive cleaning and servicing operations

To ensure that your device operates with precision and reliability for as long as possible, it is essential to perform the following servicing routines regularly.

12.1.1 During operation

Use of the filter included and the inlet pipe in order to protect the device against contamination. Make sure the device is only used inside a building.

12.1.2 Every 4 weeks

Check the bacterial filter for soiling. For this purpose the inlet and outlet of the filter must be connected to the differential pressure port using two tees. In this way the pressure drop above the filter can be measured. The pressure drop must not exceed a value of 2 mbar at a flow of 60 L/min. Otherwise the filter must be replaced.

12.1.3 Every 12 months

Factory calibration and servicing to ensure reliable measurement; it may only be performed by IMT Analytics AG or an authorised partner.

To have CITREX H4 calibrated at the manufacturer's, IMT Analytics AG, visit the website www.imtanalytics.com/easycal

The EasyCal service makes it possible for users to have CITREX H4 calibrated and adjusted quickly and easily. The annual servicing procedure is also performed.

13 Accessories and spare parts

On the website www.imtanalytics.com you will find the original spare parts and other products from IMT Analytics.

Ordering address:

IMT Analytics AG
Gewerbstrasse 8
CH-9470 Buchs, Switzerland

Tel: +41 (0) 81 750 67 10

Email: sales@imtanalytics.com

Orders can also be placed in our Webstore.

13.1 Accessories table

Options

302.159.000	Warranty extension (plus 2 years) CITREX H4
-------------	---

Service

000.000.012	Calibration and Servicing CITREX H4
000.000.023	ISO17025 Calibration and Servicing CITREX H4
000.000.014	Receiving inspection of CITREX H4
302.160.000	Triple Calibration and Servicing Package for CITREX H4

Accessories and Consumables

300.548.000	Adapter set
301.997.000	Car adapter for CITREX
302.077.000	Laminar inlet pipe
304.161.000	Black protective pouch for CITREX
304.161.001	Red protective pouch for CITREX
304.161.002	Blue protective pouch for CITREX
500.030.000	High-pressure adapter DISS O ₂
500.030.002	High-pressure adapter DISS Air
301.851.000	MicroSD memory card
302.075.000	RS-232 interface cable
301.672.000	Analog output terminal connector
301.655.000	Blind plug for oxygen connector (rubber)
302.178.000	Blind plug for oxygen connector (solid)
301.624.000	Oxygen sensor with mono jack
302.531.000	Bacterial filter RT019
304.714.000	CITREX stand

Spare parts

301.936.000	Carrying case for CITREX H4
301.625.000	Battery for CITREX
301.563.000	Network cable
301.673.000	USB cable for CITREX
301.653.000	Oxygen sensor cable
304.578.000	Power supply plug for CITREX
302.780.000	Flow channel protective cap

Table 8: Accessories

14 Disposal

Disposal of the device is the operator's responsibility. The device can ...

- be delivered, carriage free and duty paid, to the manufacturer for disposal.
- be handed over to a licensed private or public collection company.
- be professionally broken down into its constituent parts by the operator and be recycled or disposed of in accordance with regulations.

In the case of self-disposal the disposal regulations are country-specific and are contained in relevant laws and ordinances. These codes of conduct must be obtained from the authorities responsible.

In this context, wastes must be recycled or destroyed ...

- without endangering human health.
- without using processes or methods that harm the environment, especially water, air, soil, animals and plants.
- without causing noise or odour nuisances.
- without having a detrimental effect on the surroundings or landscape.

15 Directives and approvals

- CE
- CAN/CSA-C22.2 No. 61010-1-12
- UL Std. No. 61010-1 (3rd Edition)
- IEC 61010-1 2010
- IEC 61326-1 2012
- ETSI EN 301 489-17 V3.1.0
- FCC Part 15, Subpart B, Digital Devices, Emission Class B

CE Declaration of Conformity

2014/35/EU (LVD)

DIRECTIVE 2014/35/EU OF THE EUROPEAN PARLIAMENT AND OF THE COUNCIL of 26 February 2014 on the harmonisation of the laws of the Member States relating to the making available on the market of electrical equipment designed for use within certain voltage limits tested according to EN61010-1:2010

2014/30/EU (EMC)

DIRECTIVE 2014/30/EU OF THE EUROPEAN PARLIAMENT AND OF THE COUNCIL of 26 February 2014 on the harmonisation of the laws of the Member States relating to electromagnetic compatibility tested according to EN61326-1:2013

16 Specifications

16.1 Measurement parameters

Flow and pressure measurement	Measuring range	Accuracy
Air and N₂		
Flow measurement	±300 sL/min ^{***}	±1.9% * or ±0.1 sL/min ^{**}
Temperature compensated	Yes	
Ambient pressure compensated	Yes	
Channel pressure compensated	Yes	-50–600 mbar
O₂ / air mixtures		
Flow measurement	±300 sL/min ^{***}	±1.9% * or ±0.1 sL/min ^{**}
Temperature compensated	Yes	
Ambient pressure compensated	Yes	
Channel pressure compensated	Yes	-50–600 mbar
CO₂		
Flow measurement	±140 sL/min ^{***}	3% * or ±0.1 sL/min ^{**}
Temperature compensated	Yes	25–30°C
Ambient pressure compensated	Yes	
Channel pressure compensated	Yes	-50–600 mbar
Heliox (21% O₂/79% He)		
Flow measurement	±300 sL/min ^{***}	±4% * or ±0.3 sL/min ^{**}
Temperature compensated	Yes	25–30°C
Ambient pressure compensated	Yes	
Channel pressure compensated	Yes	-50–600 mbar
N₂O / O₂ mixtures		
Flow measurement	±80 sL/min ^{***}	±4% * or ±0.3 sL/min ^{**}
Temperature compensated	Yes	25–30°C
Ambient pressure compensated	Yes	
Channel pressure compensated	Yes	-50–600 mbar
Pressure		
High	0–10 bar	±1% * or ±10 mbar ^{**}
Difference	±200 mbar	±0.75% * or ±0.1 mbar ^{**}
In flow channel	-50–150 mbar	±0.75% * or ±0.1 mbar ^{**}
Barometer	500–1150 mbar	±1% * or ±5 mbar ^{**}

Table 9: Measurement parameters

Additional readings	Measuring range	Accuracy
Oxygen concentration (pressure compensated \leq 150 mbar)	0–100 %	$\pm 1\% \text{O}_2^{**}$
Gas temperature****	0–50°C	$\pm 1.75\%^*$ or $\pm 0.5^\circ\text{C}^{**}$
Gas type	Air, Air/O ₂ , N ₂ O/O ₂ , Heliox (21% O ₂), N ₂ , CO ₂	
Gas Standard	ATP, ATPD, ATPS, AP21, STP, STPH, BTPS, BTPS-A, BTPD, BTPD-A, 0/1013, 20/981, 15/1013, 25/991, 20/1013, NTPD, NTPS	

Units of measurement

Flow	L/min, L/s, cfm, mL/min, mL/s	
Pressure	bar, mbar, cmH ₂ O, inH ₂ O, Torr, inHg, hPa, kPa, mmHg, PSI	

Table 10: Additional readings

It is the larger tolerance that applies: * Tolerance in relation to the reading ** Absolute tolerance

*** In this User Manual the unit sL/min is based on ambient conditions of 0°C and 1013.25 mbar (DIN1343)

**** CITREX H4 measures gas temperature inside the measurement channel. While CITREX H4 is warming up, the temperature of the measurement channel, and hence also the temperature of the gas inside the measurement channel, rises at the same time. The measurement channel volume is relatively small, even for relatively high volumetric flows (e.g. PIF @ 60L/min). If the temperature of the gas on entering CITREX H4 is compared with gas temperature in the measurement channel, it becomes evident that the temperature in the measurement channel is higher. Therefore the temperature of the gas entering the CITREX H4 measurement channel should not be expected to equal the temperature displayed on the screen because the temperature displayed is measured inside the CITREX H4 measurement channel.

Ventilation parameters		Measuring range	Accuracy
Rate	Breaths/min	1–1000 breaths/ min.	± 1 breath or $\pm 2.5\%^{**}$
Time	T _i , T _e	0.05–60 s	± 0.02 s
Ratio	I:E	1:300–300:1	$\pm 2.5\%^*$
	T _i /T _{cyc}	0–100 %	$\pm 5\%^*$
Tidal volume	V _{ti} , V _{te}	± 10 sL	$\pm 2\%^*$ or ± 0.20 mL (> 6 sL/min)**
Peak flow	PF _{Insp} /PF _{Exp}	± 300 sL/min	$\pm 1.9\%^*$ or ± 0.1 sL/min**
Pressure	P _{Peak} , P _{Mean} , PEEP, P _{Plateau} , IPAP	0–150 mbar	$\pm 0.75\%^*$ or ± 0.1 mbar**
Compliance	C _{Stat}	0–1000 mL/mbar	$\pm 3\%^*$ or ± 1 mL/mbar**
Trigger	Adult, Pediatric, HFO Flow, Pressure and External		

Table 11: Ventilation parameters

General information

Screen	1.7" colour display
Real-time curves	Flow, pressure, volume, temperature, oxygen, ventilation parameters
Interfaces	RS-232, USB, Ethernet, CAN, Analog Out, TTL,
AC input	100–240 VAC (50/60 Hz)
Battery operation	4 hours
Dimensions (W × D × H)	11.4 × 7 × 6 cm
Weight	0.4 kg
Calibration interval	Once a year
Memory card	Yes

Operating data

Ambient temperature	15–40°C (59–104°F)
Air humidity	10–90% RH
Ambient pressure	783–1150 mbar
Storage and transport conditions	–10–60°C (14–140°F) at 5–95% RH
Degree of soiling	Degree of soiling 2, to IEC 61010-1

Table 12: General information and operating data

It is the larger tolerance that applies: * Tolerance in relation to the reading ** Absolute tolerance

*** In this User Manual the unit sL/min is based on ambient conditions of 0°C and 1013.25 mbar (DIN1343)

16.2 Interface definition

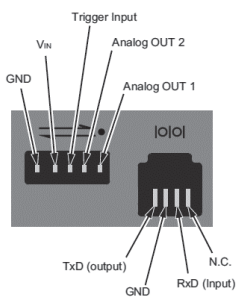

Interface	Pin assignment	Range
Analog OUT	Pin 1: Analog OUT 1 Pin 2: Analog OUT 2 Pin 3: Trigger Input Pin 4: VIN Pin 5: GND	0–5 VDC ± 1.8%, load ≥ 5 kΩ 0–5 VDC ± 1.8%, load ≥ 5 kΩ 5–24 VDC 12 VDC ± 20%–24 VDC ± 20%
RS-232	Pin 1: NC Pin 2: RxD (Input) Pin 3: TxD (Output) Pin 4: GND	
CAN	Pin 1: VIN Pin 2: CAN _H Pin 3: CAN _L Pin 4: Pin 5: Pin 6: GND	12 VDC ± 20%–24 VDC ± 20%

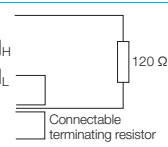

Table 13: Interfaces

Figure 35: Interface definition

16.3 Gas type

The gas type measured must agree with the setting on CITREX H4. Please select the correct gas type in the settings.

The following gas types are available for selection:

- Air 100%
- Air/O₂-Man. Air/oxygen mixture according to manual input; the default is 100% O₂
- Air/O₂-Auto. Air/oxygen mixture according to sensor measurement of internal oxygen cell
- N₂O/O₂-Man. Nitrous oxide / oxygen mixture according to manual input; the default is 100% O₂
- Heliox 21% O₂/79% He
- N₂ 100%
- CO₂ 100%

Standard conditions are understood to mean defined conditions for pressure, temperature and, in some cases, humidity, which constitute the basis for converting the flow actually measured. Therefore it is essential to check which standard condition the value displayed will relate to.

The standard currently set is indicated on the numerical and graphical display.



A gas type that has not been selected properly and a gas standard that has not been selected properly can lead to measuring errors of up to 20%.

16.4 Power supply

Input voltage of the power supply unit	100–240 VAC, 50–60Hz
Supply voltage	5 VDC
Power input	2.5–6 W

16.5 Battery operation

Operating time in battery operation 4 hours*

Charging the battery A complete charging process takes 5 to 8h, depending on which connection port is used for charging. The service life of the battery is extended if the battery is charged completely only after a prompt by the device.

* This operating time is reached in non-networked operation (i.e. the interfaces are not in use or they are switched off)

17 Appendix

17.1 Principle of flow measurement

Flow in the flow channel is determined by differential pressure measurement. To build up differential pressure a linear flow element is used to provide flow resistance.

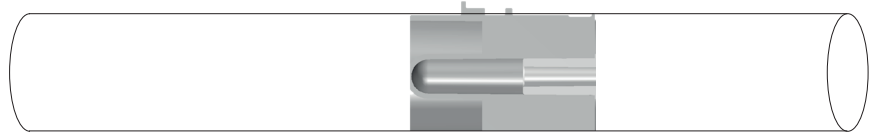

$$\Delta p = c_1 \times \eta \times Q + c_2 \times \rho \times Q^2$$

η : dynamic viscosity of the gas [Pa s]

ρ : gas density [kg/m³]

c_1, c_2 : device-specific constants (channel geometry)

Dynamic viscosity

- The viscosity of the medium is its resistance to flow and shear.
- Viscosity is extremely dependent on temperature.
- The viscosity of a medium is slightly dependent on the pressure and moisture content of the medium.

Density

- Density is the unit for the mass per unit volume of the medium.
- Viscosity is extremely dependent on temperature.
- The viscosity of a medium is slightly dependent on the pressure and moisture content of the medium.

17.2 Trigger

Triggers are used to define start and end points of cyclical signals. With regard to pressure and flow curves the trigger makes it possible to determine inhalation and exhalation. The resulting information constitutes the basis for ventilation parameter calculation. If the trigger is not set properly or if it is not possible to detect a trigger, the ventilation parameters will be calculated incorrectly or not at all.

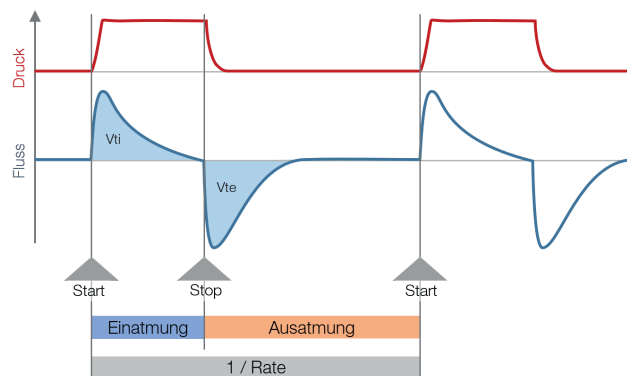

Figure 36: Trigger

17.2.1 Flow trigger

On CITREX H4 a flow trigger can be set. When the set flow is reached, the trigger is activated. In this context it is essential to specify whether at the start and end of a cycle the trigger is to be activated by a rising edge or a falling edge. Flow measurement in the flow channel serves as the trigger source. CITREX H4 can be operated bidirectionally.

17.2.2 Pressure trigger

In the case of a pressure trigger it is the pressure measured in the flow channel that serves to activate measurement. Whereby the direction of flow is of no consequence.

17.2.3 Base flow

Base flow is a constant flow that must not be included in volume calculation. If, for example, a system has a defined leak, resulting in a constant discharge of 3 L/min, those 3 L/min are not included in the inspiratory volume. The 3 L/min can be entered as a trigger setting so they will not be taken into account.

17.2.4 Delay

With a delay it is possible to filter out signal errors or noise and prevent false triggering. As a result, a trigger is only activated if the set trigger level continues to apply after the delay time. If the trigger level is no longer reached after the delay time, no trigger is activated. The delay time can be set.

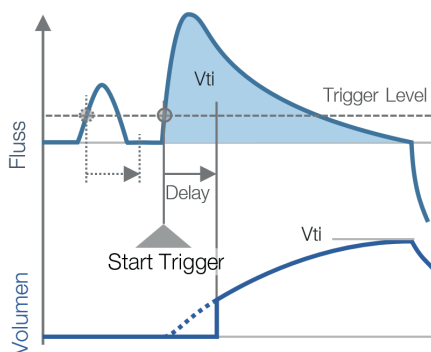

Figure 37: Delay

17.3 Measurement parameters and units

Pressure readings	Measurement parameter	Designation	Units of measurement
	Ambient pressure Pressure high Pressure in flow channel high Differential pressure	P_{Atmo} P_{High} $P_{Channel}$ P_{Diff}	mbar, bar, inH ₂ O, cmH ₂ O, psi, Torr, inHg, mmHg, hPa, kPa
Flow readings	Measurement parameter	Designation	Units of measurement
	Flow	Flow	L/min, mL/min, cfm, L/s, mL/s
Meteorological readings	Measurement parameter	Designation	Units of measurement
	Temperature Oxygen content Volume	Temp. O_2 Volume	°C, K, °F % mL, L, cf
Gas concentrations	Measurement parameter	Designation	Units of measurement
	Gas concentration Partial pressure	Gas concentration Partial pressure	% mbar, bar, inH ₂ O, cmH ₂ O, psi, Torr, inHg, mmHg, hPa, kPa
Ventilation parameters	Measurement parameter	Designation	Units of measurement
	Positive end-expiratory pressure Mean pressure Inspiratory positive airway pressure Maximum pressure Plateau pressure	$PEEP$ P_{Mean} $IPAP$ P_{Peak} $P_{Plateau}$	mbar, bar, inH ₂ O, cmH ₂ O, psi, Torr, inHg, mmHg, hPa, kPa
	Expiratory minute volume Inspiratory minute volume Inspiratory peak flow Expiratory peak flow	V_e V_i PF_{Insp} PF_{Exp}	L/min, mL/min, cfm, L/s, mL/s
	Expiratory volume Inspiratory volume Ventilation rate Inspiratory/expiratory ratio Expiratory time Inspiratory time Compliance	V_{te} V_{ti} Rate I:E T_e T_i C_{Stat}	mL, L, cf mL, L, cf Breaths/min s s mL/mbar, L/mbar, mL/cmH ₂ O, mL/cmH ₂ O

Table 14: Measurement parameters and units

17.4 Gas standards for flow and volume readings

CITREX H4 converts the flow and volume readings measured in the device to match the conditions of the standard selected. The following gas standards are supported by CITREX H4.

Gas Standard	Abbreviation	Pressure	Temperature	Relative humidity
Ambient Temperature and Pressure	ATP	Current ambient pressure	Current gas temperature	Current gas humidity
Ambient Temperature and Pressure Dry	ATPD	Current ambient pressure	Current gas temperature	0 %
Ambient Temperature and Pressure Saturated	ATPS	Current ambient pressure	Current gas temperature	100 %
Ambient Pressure at 21 °C	AP21	Current ambient pressure	21.0 °C (70 °F)	Current gas humidity
Standard Conditions USA	STP	1013.25 mbar (760 mmHg)	21.0 °C (70 °F)	0 %
Standard Conditions USA Humid	STPH	1013.25 mbar (760 mmHg)	21.0 °C (70 °F)	Current gas humidity
Body Temperature and Pressure, Saturated	BTPS	Current ambient pressure + channel pressure	37.0 °C (99 °F)	100 %
Body Temperature and (Ambient) Pressure Saturated according to ISO 80601-2-12:2011	BTPS-A	Current ambient pressure	37.0 °C (99 °F)	100 %
Body Temperature and Pressure Dry	BTPD	Current ambient pressure + channel pressure	37.0 °C (99 °F)	0 %
Body Temperature And (Ambient) Pressure Dry	BTPD-A	Current ambient pressure	37.0 °C (99 °F)	0 %
Standard Conditions to DIN1343	0/1013	1013.25 mbar (760 mmHg)	0.0 °C (32 °F)	0 %
Standard Conditions to ISO 1-1975 (DIN 102)	20/981	981 mbar (736 mmHg)	20.0 °C (68 °F)	0 %
API Standard Conditions	15/1013	1013.25 mbar (14.7 psia)	15.0 °C (60 °F)	0 %
Cummings Standard	25/991	991 mbar (500 ft altitude)	25.0 °C (77 °F)	0 %
20 °C/1013 mbar	20/1013	1013.25 mbar (760 mmHg)	20.0 °C (68 °F)	0 %
Normal Temperature and Pressure	NTPD	1013.25 mbar (760 mmHg)	20.0 °C (68 °F)	0 %
Normal Temperature and Pressure, Saturated	NTPS	1013.25 mbar (760 mmHg)	20.0 °C (68 °F)	100 %

Table 15: Gas standards for flow and volume readings

17.5 Conversion factors

Value	Equivalent		
1 mbar	0.001	bar	
	100	Pa	
	1	hPa	
	0.1	kPa	
	0.75006	torr	(760 torr = 1 atm.)
	0.75006	mmHg	(at 0 °C)
	0.02953	inHg	(at 0 °C)
	1.01974	cmH ₂ O	(at 4 °C)
	0.40147	inH ₂ O	(at 4 °C)
	0.01450	psi, psia	
1 bar	1000	mbar	
	0.1	Pa	
	1000	hPa	
	100	kPa	
	750.06	torr	(760 torr = 1 atm.)
	750.06	mmHg	(at 0 °C)
	29.53	inHg	(at 0 °C)
	1019.74	cmH ₂ O	(at 4 °C)
	401.47	inH ₂ O	(at 4 °C)
	14.50	psi, psia	

Table 16: Conversion factors

17.6 List of tables

Table 1: Symbol explanation	8
Table 2: Scope of delivery	9
Table 3: Description of electrical interfaces	16
Table 4: User controls	19
Table 5: Trigger settings	21
Table 6: Numerical values	24
Table 7: Folder structure of CITREX H4	35
Table 8: Accessories	37
Table 9: Measurement parameters	40
Table 10: Additional readings	41
Table 11: Ventilation parameters	41
Table 12: General information and operating data	42
Table 13: Interfaces	42
Table 14: Measurement parameters and units	46
Table 15: Gas standards for flow and volume readings	47
Table 16: Conversion factors	48

17.7 List of figures

Figure 1: Power supply	10
Figure 2: Flow channel	11
Figure 3: Differential pressure connector	12
Figure 4: High-pressure connector	13
Figure 5: Oxygen sensor holder	14
Figure 6: Protective cap	14
Figure 7: Screwing in the oxygen sensor	15
Figure 8: Oxygen sensor cable	15
Figure 9: Electrical interfaces	16
Figure 10: Change battery	17
Figure 11: User controls	19
Figure 12: Info display	20
Figure 13: Battery indicator	20
Figure 14: Ethernet interface	20
Figure 15: Trigger	21
Figure 16: Gas standard	21
Figure 17: Gas type	22
Figure 18: Gas humidity	22
Figure 19: Setting the X-axis	22
Figure 20: O ₂ calibration	23
Figure 21: Profiles	23
Figure 22: Numerical readings	23
Figure 23: Measurement curves	24
Figure 24: Zero calibration	26
Figure 25: Screen displays "Calibration Air"	27
Figure 26: Screen displays "Calibration Oxygen and Air"	27
Figure 27: General measurement setup	28
Figure 28: Bad setup	28
Figure 29: Measurement setup for checking ventilators	29
Figure 30: Measurement setup for gases at high pressure	29
Figure 31: Profile editor in Internet Explorer	30
Figure 32: Profile editor "configuration"	31
Figure 33: Monitoring numerics	33
Figure 34: Monitoring panels	34
Figure 35: Interface definition	42
Figure 36: Trigger	44
Figure 37: Delay	45

17.8 Index

A

Accessories 37
 Analog OUT 16
 Approvals 39

B

Battery depletion 10
 Battery operation 43

C

Calibration 26
 Calibration with air 27
 Calibration with oxygen and air 27
 CAN 16
 CAN interface 10
 Care 36
 Change battery 17
 Change units 25
 Charging the battery 43
 Cleaning 36
 Connecting the device 28
 Conversion factors 48

D

Default 32
 DHCP 33
 Differential pressure 12
 Dim screen 18
 Directives 39
 Disposal 38
 DISS adapter 13
 Dynamic viscosity 44

E

Electrical interfaces 16
 Ethernet 16

F

Flow and volume readings 47
 Flow channel 11
 Flow measurement 44

G

Gas concentrations 46
 Gas Standard 24
 Gas standards 47
 Graphical readings 24, 34

H

High pressure 13

I

Intended use 6
 Interface definition 42

M

Measurement data 35
 Measurement parameters 40, 46
 Measurements 6
 Measurement setup 28
 Mechanical connectors 11
 Meteorological readings 46
 MicroSD 16
 Monitoring option 33

N

Notes 7
 Numerical readings 23, 33

O

O₂ 26
 O₂ interface 16
 Operating time 43
 Operation 18
 Options 37
 Oxygen 26
 Oxygen sensor 14
 Oxygen sensor, installing 14

P

Parameter 25
 PC minimum requirements 32
 Personnel 7
 Power supply 10, 43
 Pressure readings 46
 Profile editor 30
 Profiles 30

R

RS-232 16

S

Safety instructions 7
 Screen lock 18
 Service life 7
 Servicing 36
 Servicing operations 36
 Settings 20
 Spare parts 37
 Specifications 40
 Start-up 9
 Switching the device on/off 18
 Symbol explanation 8

T

Trigger [44](#)

Trigger signal [24](#)

U

Units [46](#)

USB port [16](#)

User controls [19](#)

V

Ventilation parameters [6](#)

W

Web server [32](#)

Z

Zero point [26](#)

IMT.Analytics

IMT Analytics AG . Gewerbestrasse 8 . 9470 Buchs . Switzerland
T +41 81 750 67 10 . www.imtanalytics.com